

SCALE 2:1

A: SKIRT HEIGHT	B: O.A. HEIGHT (REF)
.256 [6,5]	.978 [24,85]
.354 [9]	1.077 [27,35]

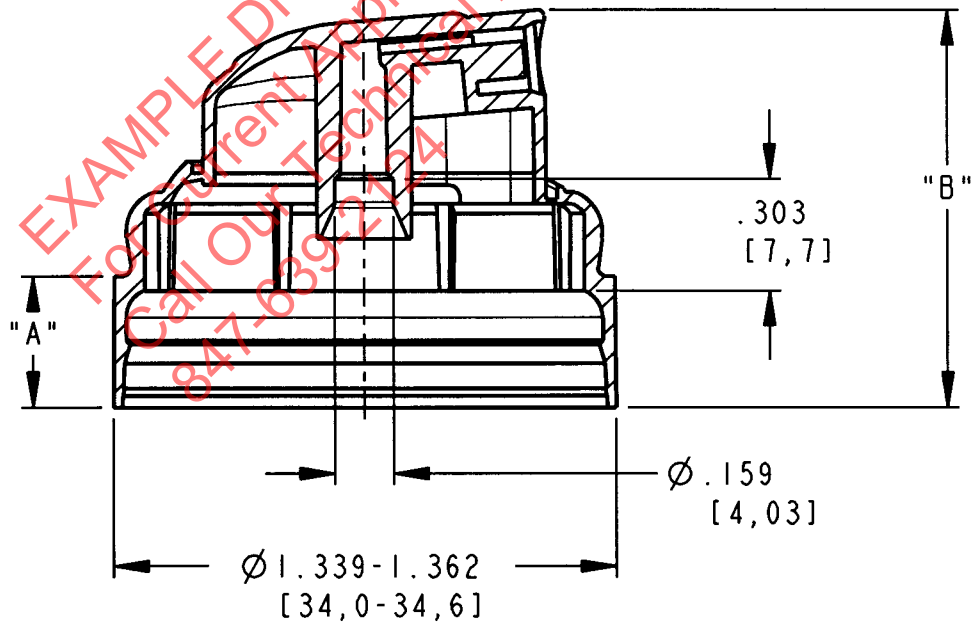

- 1 DIMENSIONS IN BRACKETS ARE IN MILLIMETERS
- 2 TOLERANCE FOR ORIFICES LESS THAN .060" (1.52 MM) DIA.: ±.002" (0.05 MM)
- 3 ALL OTHER TOLERANCES ±.005" (0.13 MM) UNLESS OTHERWISE SPECIFIED

POSSESSION OF THIS DRAWING IS AN ACKNOWLEDGEMENT THAT IT AND ITS CONTENTS ARE THE EXCLUSIVE PROPERTY OF SEAQUIST. THE ARTICLE SHOWN ON THIS DRAWING OR THE DRAWING MAY NOT BE REPRODUCED IN ANY FORM WHATSOEVER WITHOUT WRITTEN PERMISSION FROM SEAQUIST.

Title						Approved	Date
WS29 ACTUATOR						Qual Mgr	2/28/02
Drawn By	J.M.	Date	28-Feb-02	Chkd By	J.W.	Date	28-Feb-02
Material POLYPROPYLENE				Scale 2:1		Dwg No. C83-2900-20	
						Lab Mgr	HT 3/1/02
						Rev Ltr	-